

W2100-HS8-SR-ES2-EXT-0.5mA with Single Row Connector

W2100 Headstage with two external Stimulation Sites for Electrical Stimulation

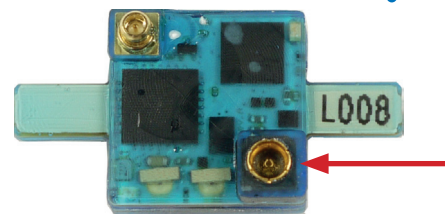

W2100-HS8-SR-ES2-EXT top side
Please use the connector for the storage battery in the lower right for orientation of the headstage.

External Connectors for Electrical Stimulation



Connectors for external stimulation (Stim 2 + Stim 1)

Connector from Mill-Max 1 mm Pitch 861-13-050-10-002000 + Magnet cuboid Magqa QA-3x1x1-N45-N on the headstage mates with Mill-Max 860-10-050-10-002000 + Magnet cuboid Magqa QA-3x1x1-N45-N.

Advantages

- The headstage is equipped with two external channels for electrical stimulation.
- The signal-to-noise ratio is excellent and most important, independent from the distance between sender and receiver.
- The headstage is additionally equipped with a triaxial gyroscope and a triaxial accelerometer by default.

Adapter for External Stimulation

The adapter for external stimulation has to be connected magnet to magnet to the headstage. Please solder a connection wire to the pads provided on the adapter.

Gyroscope and Accelerometer

The W2100 headstage is equipped with triaxial gyroscope and accelerometer sensors, which allow synchronisation with electrophysiological data.

Applications

The W2100 headstage is the ideal solution for the measurement of spikes, LFP, EEG, ECG, EMG, and ECoG. Additional inputs to the interface board allow the synchronization of the data with external devices. Use the two external stimulation channels for recording and electrical stimulation simultaneously.

W2100-B-300mAh-BB

Standard battery for the W2100-HS8-SR-E2-EXT. Please connect the battery board to the headstage.

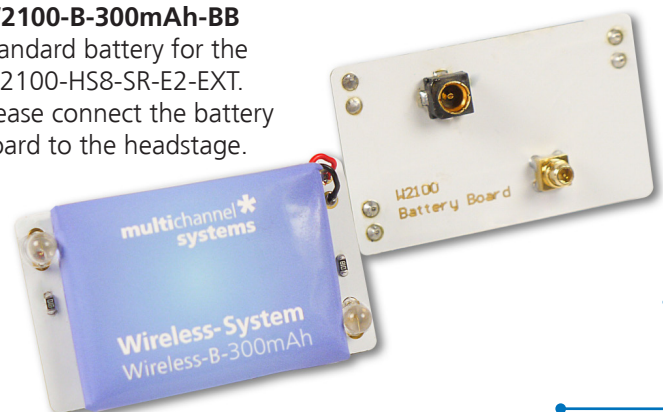

W2100-HS8-SR-ES2-EXT-0.5mA with Single Row Connector

Technical Specifications

Important: To handle the headstage, please touch the body, but not the antennae.

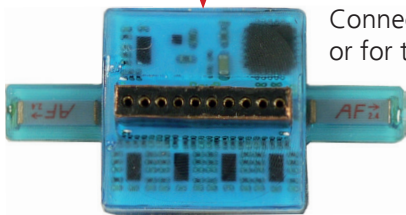

W2100-HS8-SR-ES2-EXT with single row connector bottom side
Connector for the electrode probe or for the MEW-Signal Generator.

Technical Specifications

Number of recording channels	8
Weight (without battery)	± 3.8 g
Dimensions (W x D x H) w/o antennae	15.5 mm x 15.5 mm x 7.5 mm
Distance for wireless link	5 m and more under normal conditions

W2100 Headstage with single row connector

Diagram of the bottom side with pin layout. Please orientate the headstage as shown in the diagram.

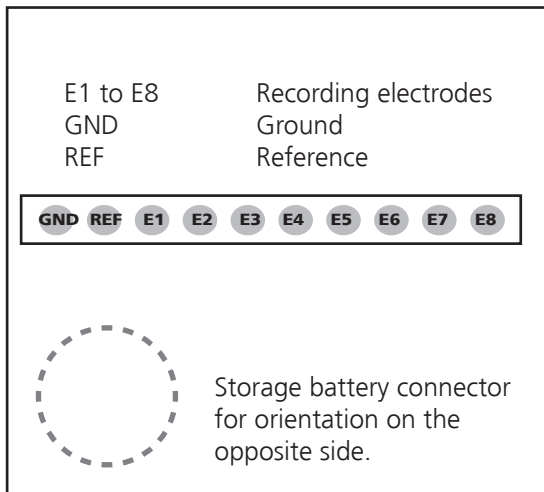

Connector for this Headstage single row precession socket

(1.27 mm, round pin)

Preci-Dip 851-87-010-10-001101

The connector mates with a standard single row 1.27 mm pin connector such as: Preci-Dip 850-10-010-10-001101
www.fischerelektronik.de: SLR 1 025
 Mill-Max .050" Grid, Series 850, 851, 852, 853 (MMMCS00609-1)

Amplifier

Bandwidth: To avoid aliasing effects, the low pass depends on the sampling frequency:

High pass	1 Hz (0.1 Hz on request)			
Low pass	400 Hz	800 Hz	1 kHz	5 kHz
@ Sampling rate	@ 1 kHz	@ 2 kHz	@ 5 kHz	@ 10 - 40 kHz

Gain	101
Input impedance	1 GΩ 10 pF
Resolution	16 bit
Input voltage range	± 12.4 mV
Input noise	< 1.9 μV _{RMS}

Sampling rate (max.) in kHz

	Number of channels simultaneously		
	2	4	8
Single Headstage Mode	40	40	25
Multi Headstage Mode	10	10	10

Stimulation

Output current - 0.5 mA to + 0.5 mA @ ± 10 V compliance voltage

Rise time 10-66 %, current 0-100 μA 1.5 μs @ RL = 10 kΩ

Inertial Measurement Unit

Gyroscope, triaxial ± 8 g @ 16 bit resolution
 Accelerometer, triaxial 1000 %/s @ 16 bit resolution

Software

Operating system Windows @ 10, 8.1 (64 bit)
 Data acquisition, analysis and export software Multi Channel Suite Version 1.5.1 and higher