



8-Channel Miniature Preamplifier MPA8I Manual



Imprint

Information in this document is subject to change without notice.

No part of this document may be reproduced or transmitted without the express written permission of Multi Channel Systems MCS GmbH.

While every precaution has been taken in the preparation of this document, the publisher and the author assume no responsibility for errors or omissions, or for damages resulting from the use of information contained in this document or from the use of programs and source code that may accompany it.

In no event shall the publisher and the author be liable for any loss of profit or any other commercial damage caused or alleged to have been caused directly or indirectly by this document.

© 2019 Multi Channel Systems MCS GmbH. All rights reserved.

Printed: 11.11.2019

Multi Channel Systems MCS GmbH

Aspenhaustraße 21

72770 Reutlingen

Germany

Phone +49-71 21-909 25 - 0

Fax +49-71 21-909 25 -11

sales@multichannelsystems.com

www.multichannelsystems.com

Microsoft and Windows are registered trademarks of Microsoft Corporation. Products that are referred to in this document may be either trademarks and/or registered trademarks of their respective holders and should be noted as such. The publisher and the author make no claim to these trademark.

Table of Contents

1	Important Information and Instruction	4
1.1	Operator's Obligations	4
1.2	Guarantee and Liability	4
1.3	Important Safety Advice	5
2	Welcome to the MPA8I Miniature Preamplifier	6
3	Setting Up and Connecting the MPA	7
3.1	General Setup Recommendations	7
3.2	Testing the Noise Level of the Setup	8
4	Multi Channel Experimenter	9
5	Setting up MC_Rack	12
7	Connecting the NeuroNexus Probe	14
8	Service and Maintenance	15
9	Pin Layout	16
9.1	Power Supply	16
9.1.1	Test Model Probe	17
10	Contact Information	18
11	Technical Specifications MPA8I	19

1 Important Information and Instruction

1.1 Operator's Obligations

The operator is obliged to allow only persons to work on the device, who

- are familiar with the safety at work and accident prevention regulations and have been instructed how to use the device;
- are professionally qualified or have specialist knowledge and training and have received instruction in the use of the device;
- have read and understood the chapter on safety and the warning instructions in this manual and confirmed this with their signature.

It must be monitored at regular intervals that the operating personnel are working safely.

Personnel still undergoing training may only work on the device under the supervision of an experienced person.

1.2 Guarantee and Liability

The general conditions of sale and delivery of Multi Channel Systems MCS GmbH always apply. The operator will receive these no later than on conclusion of the contract.

Multi Channel Systems MCS GmbH makes no Guarantee as to the accuracy of any and all tests and data generated by the use of the device or the software. It is up to the user to use good laboratory practice to establish the validity of his findings.

Guarantee and liability claims in the event of injury or material damage are excluded when they are the result of one of the following.

- Improper use of the device.
- Improper installation, commissioning, operation or maintenance of the device.
- Operating the device when the safety and protective devices are defective and / or inoperable.
- Non-observance of the instructions in the manual with regard to transport, storage, installation, commissioning, operation or maintenance of the device.
- Unauthorized structural alterations to the device.
- Unauthorized modifications to the system settings.
- Inadequate monitoring of device components subject to wear.
- Improperly executed and unauthorized repairs.
- Unauthorized opening of the device or its components.
- Catastrophic events due to the effect of foreign bodies or acts of God.

1.3 Important Safety Advice



Warning: Make sure to read the following advices prior to install or to use the device and the software. If you do not fulfill all requirements stated below, this may lead to malfunctions or breakage of connected hardware, or even fatal injuries.



Warning: Obey always the rules of local regulations and laws. Only qualified personnel should be allowed to perform laboratory work. Work according to good laboratory practice to obtain best results and to minimize risks.

The product has been built to the state of the art and in accordance with recognized safety engineering rules. The device may only

- be used for its intended purpose;
- be used when in a perfect condition.

Improper use could lead to serious, even fatal injuries to the user or third parties and damage to the device itself or other material damage.



Warning: The device and the software are **not** intended for medical uses and **must not** be used on humans. MCS assumes no responsibility in any case of contravention.

Malfunctions which could impair safety should be rectified immediately.

Any physical damage of the cable, such as a broken cable, causes a physical damage of the miniature preamplifier that cannot be repaired.

Protect the device from heat. Do not autoclave!

You can clean the connectors with distilled water in an ultrasonic bath, but keep the cable away from the fluid. Dry the device with compressed air.

Use and keep the device always in a dry environment. Do not expose it to fluids or vapor for a longer period of time.

2 Welcome to the MPA8I Miniature Preamplifier



The 8-channel miniature preamplifier MPA8I is connected to the microelectrodes for providing the **initial tenfold amplification** stage.

It has additional **common ground** and **reference electrode inputs**. The reference electrode is ideally identical to the recording electrodes and placed into a comparable but inactive area or tissue. Background or noise signals that are picked up by both the reference electrode and the recording electrodes are removed.

The metal case provides **electrical shielding**. Electrode damage is prevented by the very low bias current. The **high input impedance** ensures stable long-term recordings: Ideally, the input impedance would be infinite. As low voltages are generally recorded, a high current would flow if the input impedance were low. As a result, the amplifier would not be able to deliver the current, and the voltage would break down. The miniature preamplifier has a high input impedance to avoid this problem.

Adapters for all standard microelectrodes such as NeuroNexus probes (NeuroNexus Technologies) for acute and chronic implantations ensure a close proximity to the probe to minimize signal loss and cross talk. Adapters are not included in the standard scope of delivery and have to be ordered separately. For custom adapters, please ask your local retailer or contact Multi Channel Systems MCS GmbH.

3 Setting Up and Connecting the MPA

3.1 General Setup Recommendations

In the following, you find general recommendations for the installation. If you are using NeuroNexus probe adapters available from MCS, please refer to the following chapters for more information.

Miniature preamplifier setup

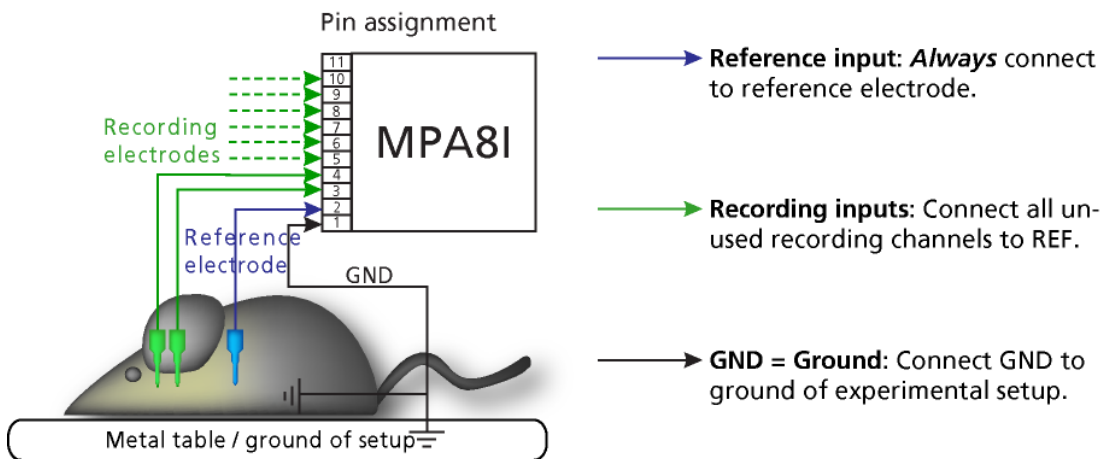

Important: It is important that the **complete setup** refers to a **single common ground**. The reference input has always to be connected. It is recommended to use a reference electrode. However, if you are not using a reference electrode, connect the reference input to ground (GND). Otherwise, noise picked up by the reference input will be subtracted from the recording signals. This will either lead to signal loss or to a very high noise level.

Ground the animal with a **ground electrode** of large surface area, for example, a liquid gel adhesive electrode, that is connected to the **ground** of the setup, for example, a large metal table or a **Faraday cage**, to avoid pickup of noise from the environment. The ground electrode is best positioned in an electrically inactive region not near muscle, nor heart, for example, at the belly.

Connect the **GND input** or the metal case of the miniature preamplifier to the **common ground** of the setup. The GND input is internally connected to the metal case.

Connect the **reference electrode** to the **reference input** of the miniature preamplifier. Generally a reference electrode is inserted into non-active tissue of the experimental model. The reference electrode should be identical to the recording electrode so that both electrodes see the same background noise. This is necessary because despite the grounding, the animal's body often has not exactly a potential of zero, due to the electrode impedance, for example. The background noise is then subtracted from the recording signal, increasing the signal to noise ratio. Please note that this may not work if the complete setup is not properly grounded.

Connect the **recording electrodes** to the **recording channels** of the miniature preamplifier. You can either use single electrodes or multitrodes with the miniature preamplifier. MCS provides adapters for standard probes.

Connect all unused recording channels to the **GND input** or to the reference electrode if the reference and ground electrode of the amplifier are short circuited, to avoid noise pickup. As the total amplifier gain generally lies in the range of 1000, even very small noise signals may generate high noise signals.

If you are not using a Faraday cage, it might be necessary to shield the complete setup with aluminum foil or similar to prevent electrical interference from the outside. Connect the aluminum foil to the ground of the setup, for example, the metal table.

Troubleshooting: If you observe problems with noise, check that the ground of the setup is connected to exactly the same ground as the data acquisition computer. For example, connect the metal table to the ground / earth wire of a free power outlet (of the same electrical system), as the computer is generally connected to ground / earth via the power plug, too. Also, connect the data acquisition computer's metal case with a thick ground wire to the ground of the setup, for example, the metal table, preferably with a 4 mm plug.

3.2 Testing the Noise Level of the Setup

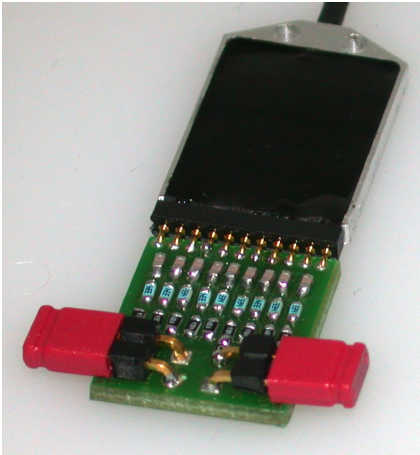

A **terminal plug** that connects all inputs to **ground**, and a **test model probe** that mimics the **electrode impedance** are available for testing the noise level of the setup.

Note: Please note that the test model probe has to be ordered separately.

All instruments were thoroughly tested at the factory site before delivery. The tests suggested below are mainly intended for optimizing and troubleshooting your setup, to exclude any damage that might have occurred during transportation, or to fulfill your own guidelines, for instance. It will take only a few minutes time and can save time and trouble in the long run. Multi Channel Systems recommends running these tests before you start your real experiments.

1. Connect the terminal plug to one MPA8I and the test model probe to the other as shown in the picture, please do not mismatch the polarity. If you have only one MPA8I, you can perform the two tests consecutively.
2. Connect the MPA8I with **test model probe** to channels 1 to 8 of the signal collector.
3. Connect the MPA8I with the **terminal plug** to channels 9 to 16 of the signal collector.
4. Make sure that all other connections are appropriate, and that your setup has an appropriate grounding and shielding as recommended in the chapter "General Setup Recommendations".

4 Multi Channel Experimenter

Double-click the Multi Channel Experimenter icon or select Multi Channel Experimenter from the "Start" menu. The program starts. The main window opens automatically: "Multi Channel Experimenter (Instance: 1)". It is possible to open up to four instances in parallel. Operation is independent for each instance.

This is your virtual rack configuration in the "Experiment Setup" window, which is blank after program start. On the left side five classes of instruments are provided: "Data Sources", "Recorder" and "Stimulators" are hardware components. The virtual instruments available up to now are divided in "General" and application specific "Neuro".

The header of the dialog contains five buttons: "Start DAQ", "Start Recording", "Load Experiment" and "Save Experiment" in the main toolbar on the left and the "Menu" button on the right. In the bar down under the "Recording Time" and the "DAQ Time" are registered.

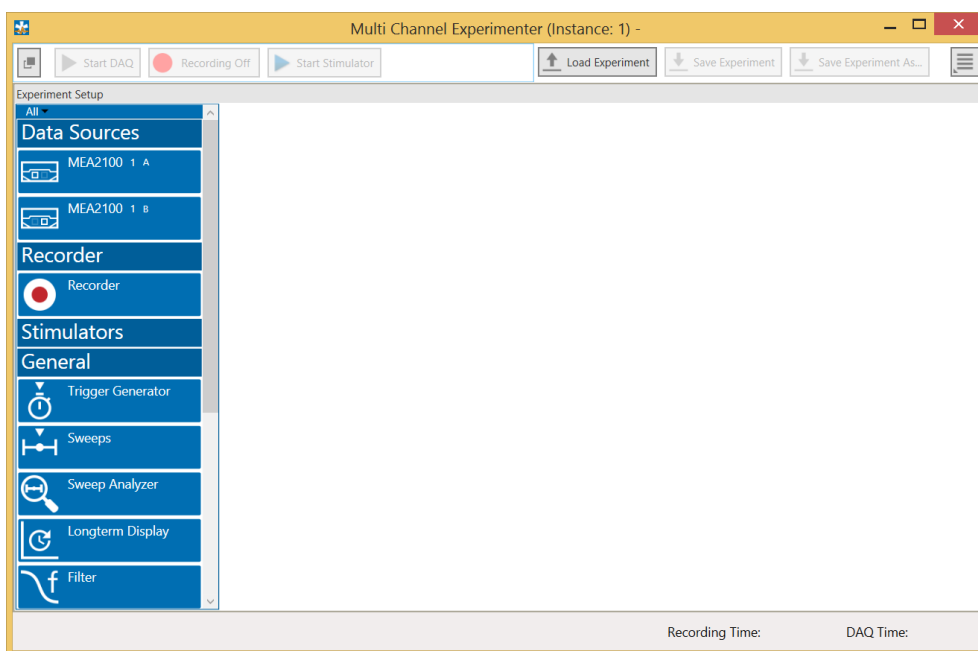

Building a Rack

It is very easy to build a rack: Please click onto the button of the desired instrument and move it via drag and drop from the left to the right side of the main window!

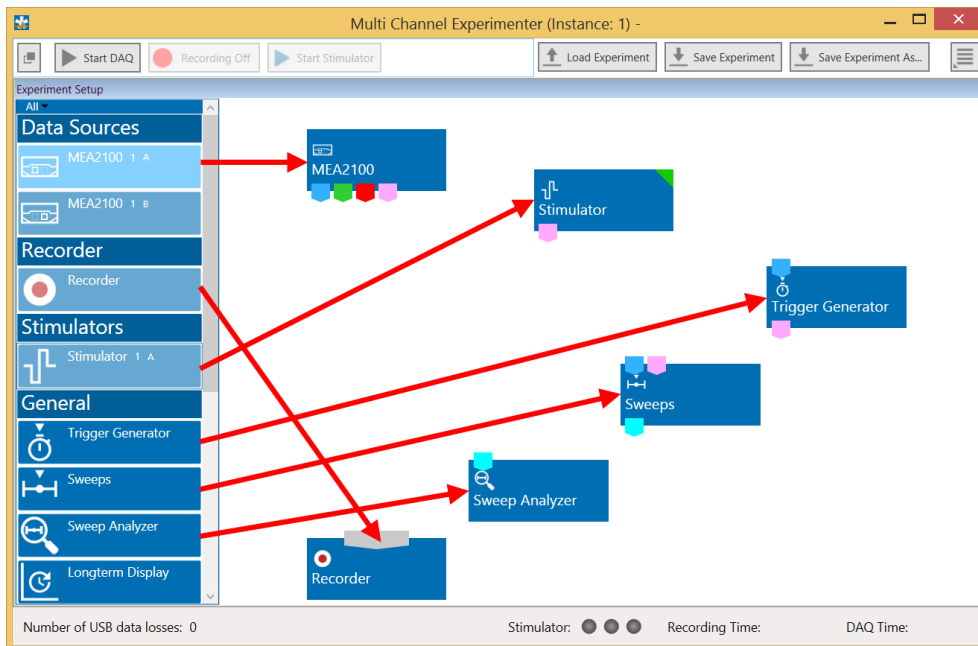

It is also easy to connect the instruments: Please click onto one of the symbols on the lower part of an instrument button to connect this output port via drag and drop with the input port (symbol on the upper side) of the target instrument. Please read the next chapter.

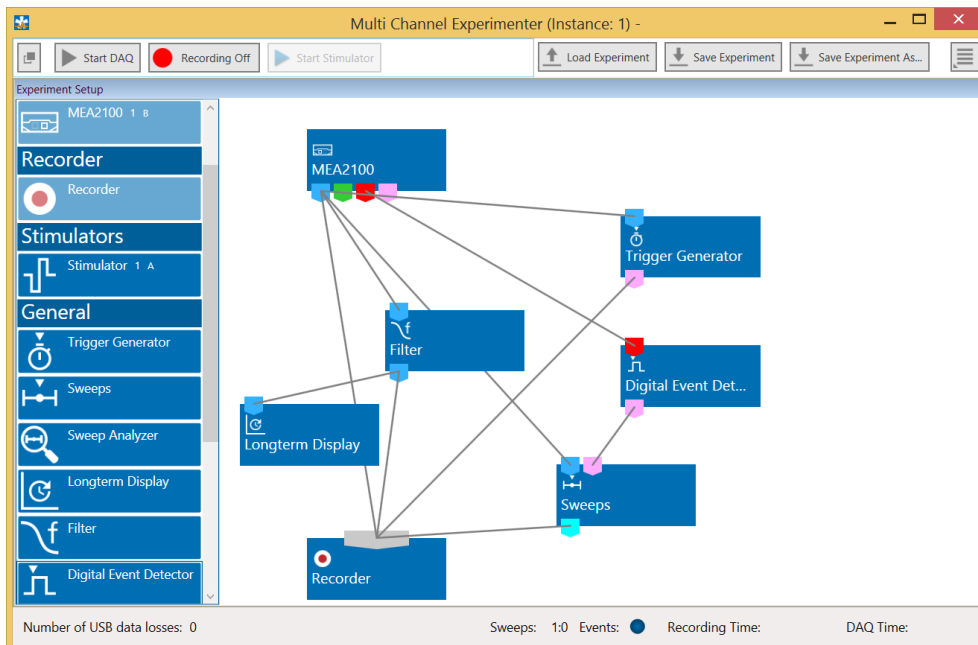

Move as many instruments as you need via drag and drop into the “Experiment Setup” window. It is possible to use the virtual tools more than one time.

Conventions for Building a Rack

Please consider the rules for connecting the instruments. The Multi Channel Experimenter program allows only connections between output ports at the lower side of the device to the input port on the upper side of the target device. The input and output ports of the devices are color coded for a better assignment of the instruments. The blue symbol represents the port for the "Electrode Raw Data". The green symbol represents the port for the "Auxiliary Analog Data". The red symbol represents the port for the "Digital Data".

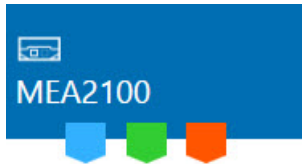

Three color coded output ports of the MEA2100 data acquisition device.

Example: Click on the blue symbol output port of the data source and connect it by drag and drop with the blue symbol input port of the filter. The electrode raw data stream will flow from the data source to the filter. Connect the blue symbol output port from the filter with the black symbol input port of the recorder.

The electrode raw data stream will flow from the filter to the recorder. The black input port of the recorder accepts all types of input data streams and you can connect more than one data stream.



5 Setting up MC_Rack

Please refer to the MC_Rack Manual for more information.

Start MC_Rack.

Open the file MPA8I_NoiseTest.rck on the installation volume (see folder Tutorial). This rack contains the virtual **MC_Card** instrument as data acquisition device with a continuous raw data display and an **Analyzer** to measure the peak-to-peak amplitude.

Click **Start** to start the recording.

— OR — Set up the rack on your own:

Click **Data Source Setup** on the **Edit** menu. Select a 1-dimensional layout. Select the number of electrode channels (at least 16).

Add the respective **data acquisition** to your virtual rack.

In the tree view pane of the virtual rack, select the **data acquisition**, and click the **Hardware** tab. Enter the total amplifier gain according to the specifications of the instruments. For example, for a miniature preamplifier with a gain of 10 and a following filter amplifier with a gain of 100, the total gain is 1000.

Select an **input voltage range** of -819.2 to $+818.8$ mV and a **sampling rate** of 10000 Hz.

On the **Edit** menu, click **Add Data Display** to add a raw data display to your virtual rack.

In the virtual rack tree view pane, select the **Display 1** and click the **Layout** tabbed page. Set up a channel map with **channels 1 to 16**.

Adjust the display ranges to **500 ms** and $\pm 50 \mu\text{V}$.

On the **Edit** menu, click **Add Analyzer** to add an **Analyzer** to the virtual rack. Select all or two typical channels on the **Channels** tabbed page. Select the **Peak-Peak Amplitude** parameter on the **Analyzer** tabbed page.

On the **Edit** menu, click **Add Parameter Display** to add a **Parameter Display** to the virtual rack.

In the virtual rack tree view, select the **Display 2** and click the **Layout** tabbed page. Set up a channel map with all channels that were assigned to the **Analyzer**.

Click the **Ranges** tabbed page and enter 0 to 10 s for the x- range and 0 to 100 μV for the y- range.

Typical Results

Typical results of this test are shown in the following screen shot. The filter amplifier used for this test had a gain of 100 and a bandwidth of 0.5 to 5000 Hz (FA64I-100-0.5-5000). If you use a filter amplifier with a narrower bandwidth, you can generally expect a slightly lower noise level.

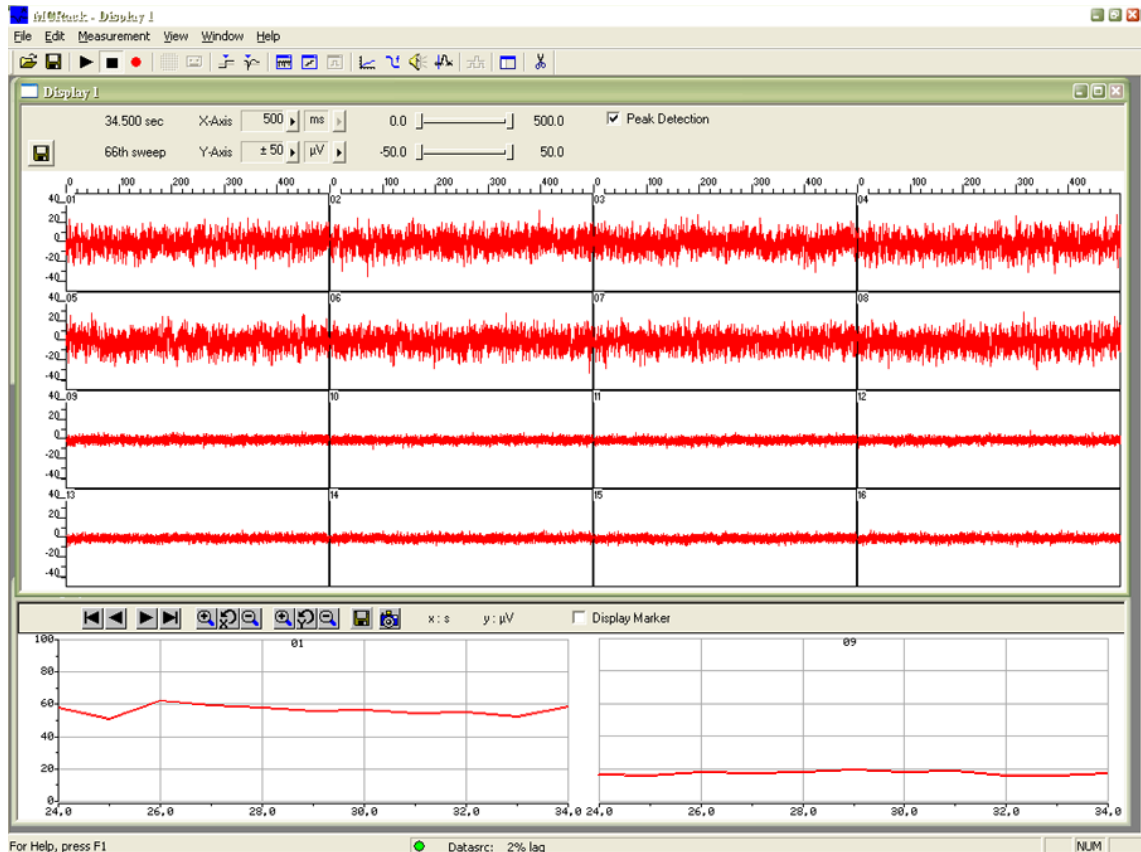

Noise level test with MPA8I and FA64I-100-0.5-5000 filter amplifier.

The noise level is 60 μV peak to peak with the provided test model probe (channels 1–8) and 20 μV peak to peak with grounded inputs (channels 9–16). The top window shows raw data; the bottom window shows the extracted peak-to-peak amplitudes of channels 1 and 9. The miniature preamplifier was shielded by a metal case connected to the ground / earth of the test lab.

6 Connecting the NeuroNexus Probe

Complete Setup with NeuroNexus Probe and two MPA8Is

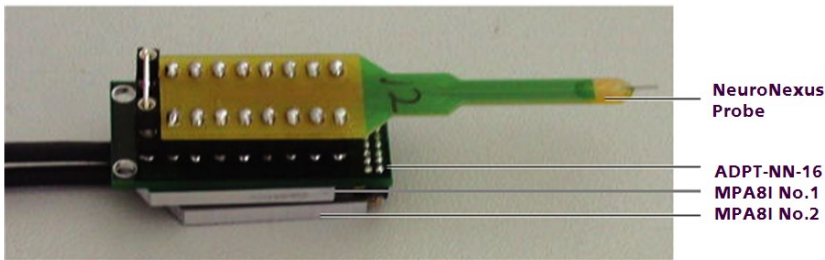

Insert one pin array of the NeuroNexus Probe adapter into one MPA8I, and the other into the second MPA8I. Make sure that the orientation of the MPA8I is correct (see illustration).

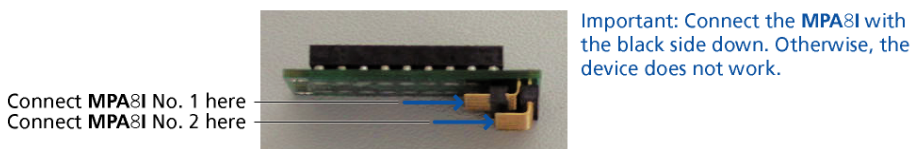

Channel assignment, output pins connected to MPA8I

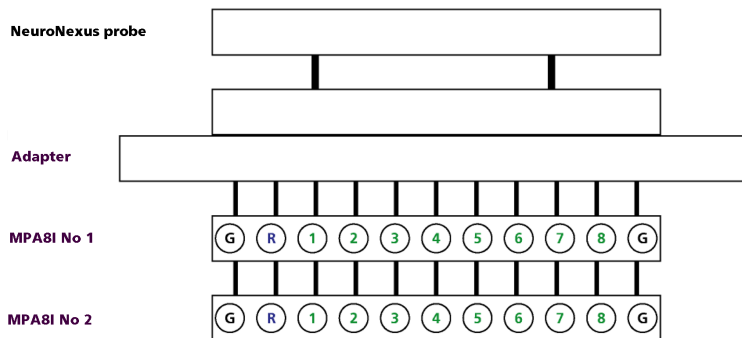

Channel assignment, output pins.

Shown are the output pins of the adapter that are connected to the miniature preamplifiers MPA8I when looking directly at the pins. The numbered channels are the ground channels (G), the reference channel (R), and the 8 recording channels (1 - 8) of the MPA8I.

Channel assignment, input pins.

Shown are the input pins of the adapter that are connected to the probe. The labelled channels are the ground channel (G), the reference channel (R), and the 8 recording channels (1 - 8) of the MPA8I. G and R have been connected together as factory-default settings. You can change this connection to meet your requirements.

Channel assignment, input pins (connected to the probe)

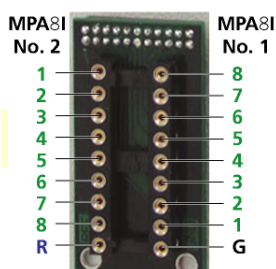

Important: Operation of the MPA8I is differential. The reference channel R has to be used for obtaining a proper signal.

7 Service and Maintenance

Cleaning the Connectors



Warning: It is recommended to avoid the use of cleaning solutions to avoid corrosion. If a wet cleaning is required, use distilled water. Make sure that only the connectors touch the liquid; do not submerge the miniature preamplifier or the cable. Otherwise, you can fatally damage the electronics.

Clean the connectors with 70 % alcohol and cotton swabs from time to time.

If this does not provide satisfying results, insert only the connectors into a small beaker with acetone or alcohol and treat them in an ultrasonic bath for 10 to 20 s. Air-dry the miniature preamplifier for about 5 min before use.

You can also clean the connectors with distilled water in an ultra sonic bath. Dry the connectors with compressed air immediately after sonication and let the amplifier air dry for at least 6 h before use.

Sterilization



Warning: Do not autoclave or sterilize miniature preamplifiers by high heat (above 70 °C) or vapor. The resin is not heat-stable and may deform under heat. Vapor can lead to a corrosion of the electronics.

Miniature preamplifiers can be sterilized with standard methods that are not based on high heat or vapor, for example, with 70 % ethanol, UV-light, or by thermal sterilization in an oven at 56 °C with an incubation time of 8 hours.

8 Pin Layout

8.1 Power Supply

Supply voltage is applied to the output connector pins 8 and 15. The voltage source should supply a stable noise free voltage. Do not exceed the maximum voltage.

Pin 8: -3 V to -8 V

Pin 15: +3 V to +8 V



Warning: Do not mismatch the polarity of the power supply. A false connection may damage the unit.

Input Connector

8-Channel Miniature Preamplifier inputs

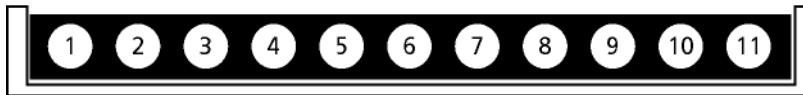

Please note that the black side is considered the top side.

1	Ground (GND)
2	Reference input
3 ... 10	Recording channels 1 to 8
11	Ground (GND)

Output Connector (Male)

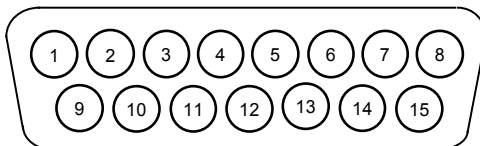

1	Ground (GND)
9	Signal ground*
2, 10, 3, 11, 4, 12, 5, 13	Recording channels 1 to 8
6, 14, 7	Ground (GND)
15	Positive supply voltage
8	Negative supply voltage

* = Connected to the ground of the amplifier.

The signal ground is used as the reference for the following filter amplifier.

8.1.1 Test Model Probe

Test model probe for MPA8I pin layout

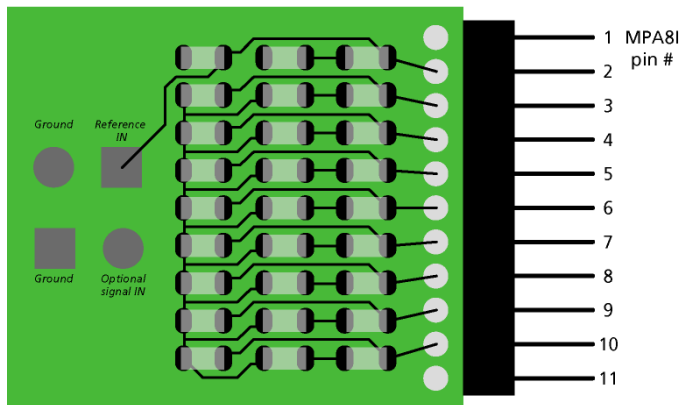

Model test probe for MPA - circuit

Test signal input jumper

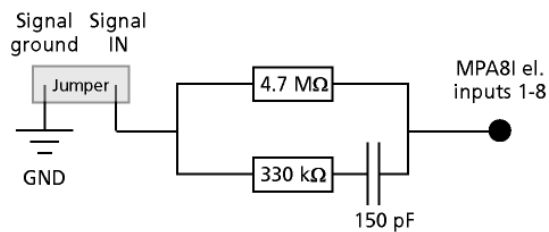

Reference input jumper

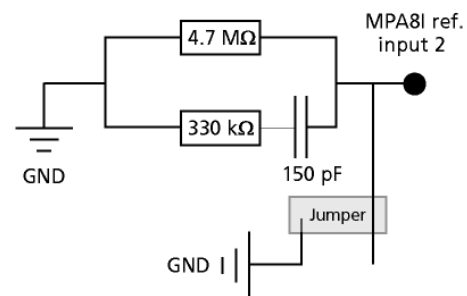

Test signal IN: You can use the jumper to connect the signal input pin (Signal IN) to ground (standard situation for a noise level test), or you can connect a data source, for example, a sine wave generator to the input (and the ground of the test signal to the signal ground input) to test the signal distribution. The input signal is distributed across all recording channels.

REF IN: The standard situation in an experiment should be that the reference electrode has properties identical or close to the recording electrodes. You can remove the jumper to connect the reference output of the test model probe to the same resistors as the recording channels to mimic the experimental situation, or you can use the jumper to connect the reference output to ground.

DC resistance	4.7 MΩ
Dynamic	330 kΩ
Capacitance	150 pF

9 Contact Information

Local retailer

Please see the list of official MCS distributors on the MCS web site.

Mailing list

If you have subscribed to the ME-System mailing list, you will be automatically informed about new software releases, upcoming events, and other news on the product line. You can subscribe to the list on the contact form of the MCS web site.

www.multichannelsystems.com

10 Technical Specifications MPA8I

Operating temperature	0° C to 50° C
Storage temperature	0° C to 50° C
Relative humidity	10 % to 85 % non-condensing
Dimensions (W x D x H)	17 x 25 x 1.8 mm
Weight	1.3 g w/o cable and plug, 21 g with cable and plug
Length of the cable	1.5 m
Maximum tensile strength of cable	20 N
Input connector type	Single-row precision sockets, 50 mil (1.27 mm) grid pattern, for 0.35 to 0.45 mm round pins
Supply voltage	$\pm 3 \text{ V}$ to $\pm 8 \text{ V}$ DC
Supply current	$< \pm 6 \text{ mA}$, typically $\pm 4 \text{ mA}$
Number of input channels	8
Input voltage	$\pm 500 \text{ mV}$ (with respect to a supply voltage of 5 V)
Input impedance	$10^{12} \Omega$ parallel to 10 pF
Input noise	$< 1.5 \mu\text{V}_{\text{RMS}}$ (1 Hz to 5 kHz, inputs short-circuited)
Noise density	$e_n = 15 \text{ nV} / \sqrt{\text{Hz}}$
Number of output channels	8
Output voltage	= supply voltage
Output current	max. = 10 mA
Output impedance	0 Ω
Bandwidth	DC to 50 kHz
Gain	10